

## Piede d'arredamento quadrato PI03

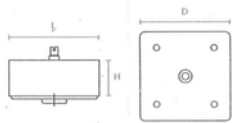

ART	Sez.piede mm.	Finitura	Altezza mm
PI 03 B AR	75X75	Alluminio	60
PI 03B CR	75X75	Cromo lucido	60

## Piede d'arredamento rettangolare PI205

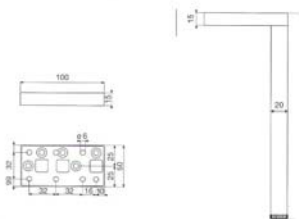

ART	Sez.piede mm.	Finitura	Altezza mm
PI 205 10 NE	20 x 50	Nero	100
PI 205 12 NE	20 x 50	Nero	120

## Piede d'arredamento Conico Famiglia 01 in resina termoplastica



Art. 106



Art. 107



ART. 117

ART	Sez.piede mm.	Finitura	Altezza mm
PI 203 12AL	Diam 45	Alluminio	120
PI 211 90AL	Diam 45	Alluminio	90
PI 213 80AL	Diam 45	Alluminio	80
PI 207 10AL	Diam 45	Alluminio	105
PI 208 10NI	Diam 45	Cromo lucido	105
PI 228 7AL	Diam 45	Alluminio	75
PI 229 7NI	Diam 45	Cromo lucido	75
PI 217 12AL	Diam 45	Alluminio	120
PI 218 12NI	Diam 45	Cromo lucido	120

## Piede d'arredamento Sagomato Famiglia 02 in resina termoplastica



Art. 203 - 211



Art. 213



Art. 207 - 208  
228 - 229



Art. 217 - 218

# Piedi per mobile a vista

## Piedi alluminio d'arredamento altezza a misura

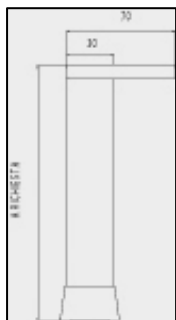

Altezza piede a misura da mm 65  
 Regolazione in altezza mm 15 circa

ART	Sez.piede mm.	Finitura	Flangia Applicabile
TU2525NS	25 x 25	Alluminio	F25
TU3030NS	30 x 30	Alluminio	F09 – F24
TU3030NI	30 x 30	Cromo lucido	F09 – F24
TU4040NS	40 x 40	Alluminio	F09 – F24
TU4040NI	40 x 40	Cromo lucido	F09 – F24
FLANGE			
ART.	Sezione mm.	Finitura	Piede applicabile
FL F09 AL	85 x 42	Alluminio	30x30 e 40x40
FL F24 AL	70 x 70	Alluminio	30x30 e 40x40
FL F25 AL	55 x 55	Alluminio	25x25

Flangia F09



Flangia F24



Flangia F25



## Piede d'arredamento Art. PI01

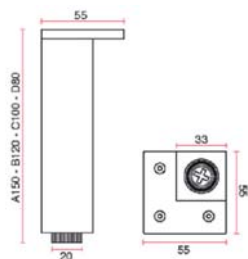

ART	Sez.piede mm.	Finitura	Altezza mm
PI01BAR	33 x 33	Alluminio	120
PI01CAR	33 x 33	Alluminio	100
PI01DAR	33 x 33	Alluminio	80

## Piede d'arredamento Art. PI02

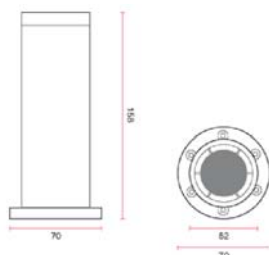

ART	Sez.piede mm.	Finitura	Altezza mm
PI02BAR	Diam. 52	Alluminio	120
PI02CAR	Diam. 52	Alluminio	100
PI02DAR	Diam. 52	Alluminio	80

# Piedini da mobile

## ART.680

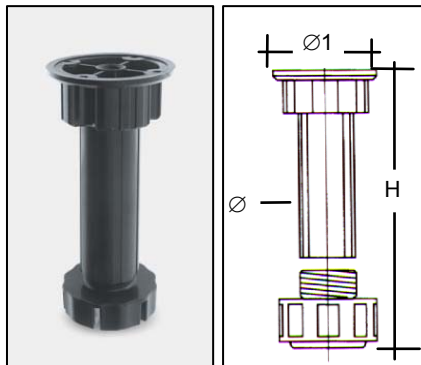

ART.	H mm	Ø mm	Ø1 mm	Finitura	PZ. Conf.
PI68010CO	100	28	60	Bianco	4
PI68012CO	120	28	60	Bianco	4
PI68015CO	150	28	60	Bianco	4

MATERIALE - Plastica con base larga R5  
REGISTRO - In altezza fino max 15mm  
CONFEZIONE - Viti fissaggio incluse

## ART.180

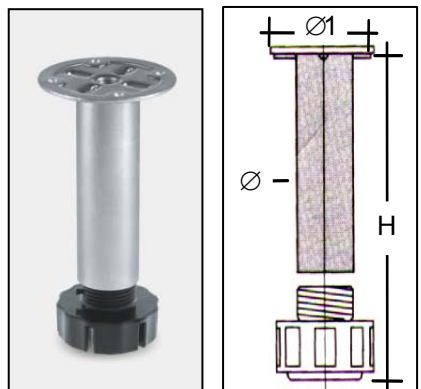

ART.	H mm	Ø mm	Ø1 mm	Finitura	PZ. Conf.
PI1826ZI	60	28	50	Zincato	4
PI1828ZI	80	28	60	Zincato	4
PI18010ZI	100	28	60	Zincato	4
PI18012ZI	120	28	60	Zincato	4
PI18015ZI	150	28	60	Zincato	4
PI18018ZI	180	28	60	Zincato	4
PI18020ZI	200	28	60	Zincato	4

MATERIALE - Ferro con base in plastica larga di serie o stretta se richiesto  
REGISTRO - In altezza fino max 15mm

## ART.130

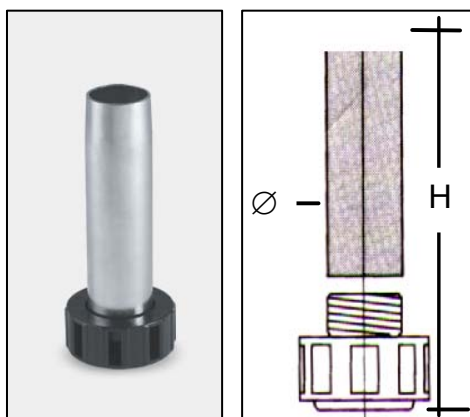

ART.	H mm	Ø mm	Finitura	PZ. Conf.
PI13010ZI	100	28	Zincato	4
PI13012ZI	120	28	Zincato	4

MATERIALE - Ferro con base in plastica grande.  
ALTEZZA - La misura H è compresa di supporto P2-P5-P8  
REGISTRO - In altezza fino max 15 mm

**P2**  
plastica bianca



**P5**  
ferro zincato



**P8**  
plastica bianca



## ART.D5 Scivolo



ART.	Finitura	Ø mm	PZ. Conf.
SCD5CO	Bianca	47	4

MATERIALE - Plastica

## ART.308



ART.	H mm	Ø mm	Finitura	PZ. Conf.
PI3084ZI	40	28	Zincato	1-100
PI3086ZI	60	28	Zincato	1-100
PI3088ZI	80	28	Zincato	1-100
PI30810ZI	100	28	Zincato	1-100
VI3084ZI	CM 4		Zincato	1-100
TA308BI			COLORE BIANCO	1-100
TA308MA			COLORE MARRONE	1-100

MATERIALE - Ferro con base in plastica

REGISTRO - In altezza fino max 30 mm con chiave a esagono 6mm

Portata fino 400 Kg.

\*Fissaggio con vite da ordinare a parte

\* Tappo da ordinare a parte e specificare colore

## Mollone ART. 125 in ferro zincato

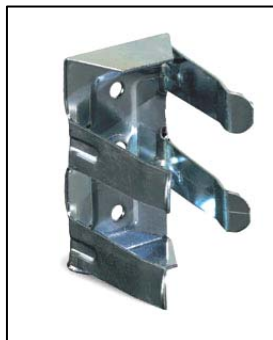

ART.	Finitura	H. mm	L. mm
MO125ZI	Zincata	55	30

## Mollone ART. 202 in ferro zincato e plastica nera

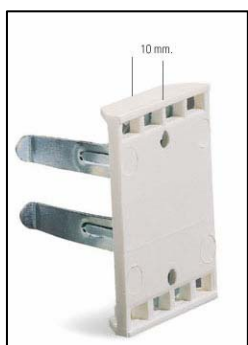

ART.	Finitura	Dim. Mollone mm.	Dim. Plastica mm.	Colore
MO202ZI	Zincata	45 x 30	52 x 37	nero

## Mollone ART. 9 in plastica per zoccoli in PVC



ART.	Finitura	PZ. Conf.
MO9CO	Bianco	4

# Piedi per mobile a vista

## Piastra di fissaggio Art.209

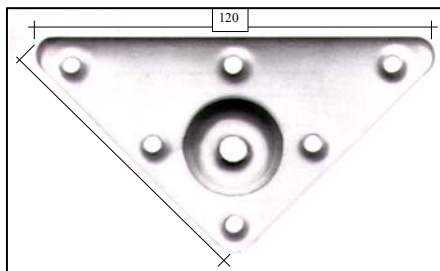

ART.	Spessore mm	Finitura	PZ. Conf.
PI209ZI	10	Zincata	1

**Materiale : Ferro**

# Piedi per mobile torniti in legno

## Piede in legno Art. 20 in Ontano



ART	Altezza mm	Ø mm	Finitura
PI20GR	185	74	Naturale non lucidato

## Piede in legno a cipolla



ART	Altezza mm	Ø mm	Finitura
PC60GR	72	60	Grezzo non lucidato
PC70GR	80	70	
PC80GR	80	75	
PC90GR	100	90	
PC100GR	100	100	
PC110GR	100	110	
PC120GR	120	120	

## Piede in legno a cipolla base piatta



ART	Altezza mm	Ø mm	Finitura
PC130GR	105	130	Grezzo non lucidato

## Piede in legno a conico base piatta



ART	Descrizione mm	Altezza cm	Perno	Finitura
PICO622FAGR	Parte alta diametro 60 Parte bassa diametro 30	22	Perno filettato m 10 x 25	Faggio grezzo

## Piede in legno a spillo



ART	Descrizione mm	Altezza cm	Perno	Finitura
PISP518FAGR	Parte alta diametro 55X55 Parte bassa diametro 27X27	18	Perno filettato m 10 x 25	Faggio grezzo

# Piedi per mobile torniti in legno

## Piede in legno conico



ART	Altezza mm	Ø mm	Finitura
PI4917030FAGR	300	50	Grezzo non lucidato
PI4917140FAGR	400		
PI4917250FAGR	500		

## Piede in legno Cilindrico per mobile o tavolini



ART	Diametro mm	Altezza cm	Perno	Finitura
PICI5533FAGR	55	30	Perno filettato m 10 x 25	Faggio grezzo

## Piede in legno quadrati per mobile o tavolini



ART	Sezione mm	Altezza cm	Perno	Finitura
PI505033FAGR	50 x 50	30	Perno filettato m 10 x 25	Faggio grezzo



# Piedini livellatori per mobili

## ART.378

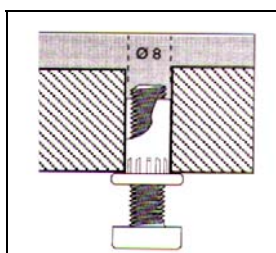

ART.	Descrizione	Finitura
PI378ZI	Piede completo	Bianco-Nero
CO396CO	TappoCopri vite	Bianco-Nero
BU378ZI	Bussola	Zinco bi.
VI198625	Vite TE	Zinco bi.

H bussola 15 mm

## ART.01 - ART.02 - ART.03 - ART.10

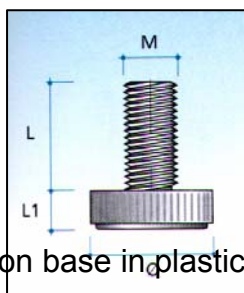

ART.	L mm	L1 mm	Ø mm	M	Finitura	Registro
PIPI01NE	20	5	22	6	Zincato	Manuale
PIPI02NE	22	6	28	8	Zincato	Manuale
PIPI03NE	25	7	32	10	Zincato	Manuale
PIPI10NE	20	7	20	6	Zincato	C/Taglio

Materiale: Ferro con base in plastica nera

## ART.05 - ART.324

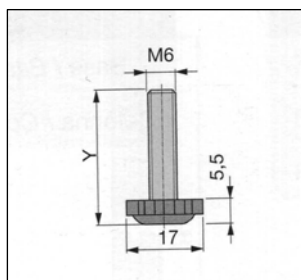

ART.	Y mm	L1 mm	Ø mm	M	Finitura	Registro
PIPI05NE	25	7	17	6	Zincato	Manuale
PI324NE	30	5.5	17	6	Zincato	Manuale

Materiale: Ferro con base in plastica nera

## ART.161

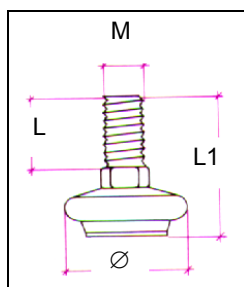
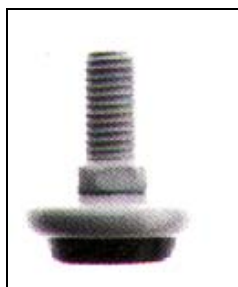

ART.	L mm	L1 mm	Ø mm	M	Finitura
PI161830NI	14	29	30	8	Nichelato
PI1611035NI	19	35	30	10	Nichelato

base in plastica nera

Materiale: Ferro

## ART.260

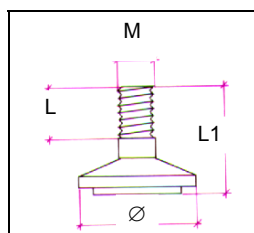

ART.	L mm	L1 mm	Ø mm	M	Finitura
PI26032NI	15	32	32	8	Nichelato
PI26032OT	15	32	32	8	Ottonato
PI2601032NI	13	32	32	10	Nichelato

Materiale: Ferro

# Piedini livellatori per mobili

## ART.282

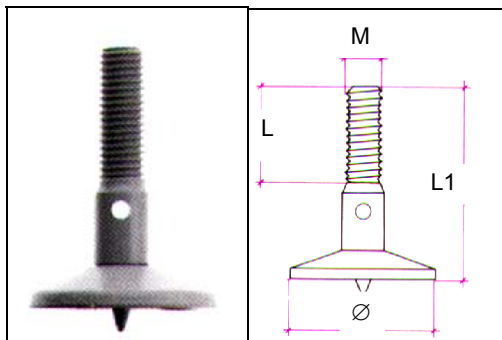

ART.	L mm	L1 mm	Ø mm	M	Finitura
PI28250OL	30	57	50	10	OTTONE

Piede in ottone con puntale per legno e foro per registro.

## ART.283

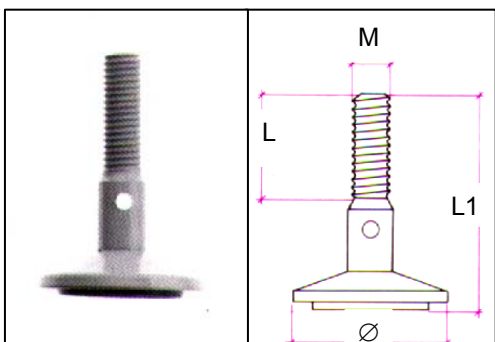

ART.	L mm	L1 mm	Ø mm	M	Finitura
PI28350OL	30	57	50	10	OTTONE

Piede in ottone con base in gomma nera e foro per registro.

## ART.327

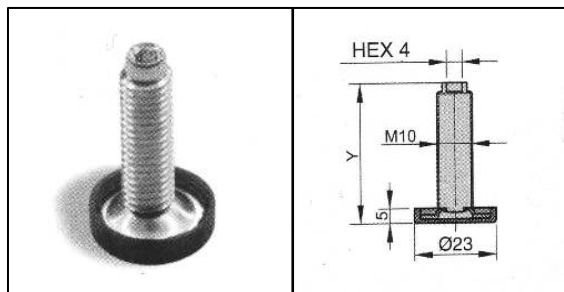

ART.	Y mm	L1 mm	Ø mm	M	Finitura	Registro
PI327NE	38	5	23	10	Zincato	Brugola

Piedino in ferro con base snodabile in plastica nera registrabile dall'alto.

## ART.300

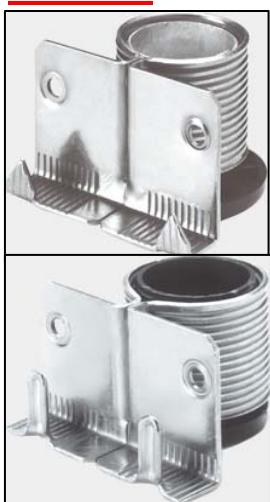

ART.	Finitura	Fissaggio
PI300EMZI	Zincato	Martello
PI300EZI	Zincato	Preforaggio

### Caratteristiche generali:

Regolazione: fino a 30mm  
 Sp. pannello: min. 12mm  
 H Zoccolo: da 20 a 100mm  
 Regolazione: chiave esagonale da 6mm  
 Fissaggio: Viti – pressione - coduli  
 Materiale: Metallo / plastica  
 Portata: 400 Kg

# Piedini livellatori per mobili

## ART.306 Diametro 12

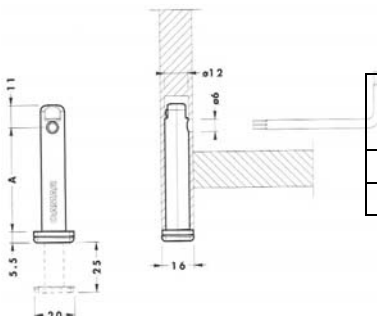
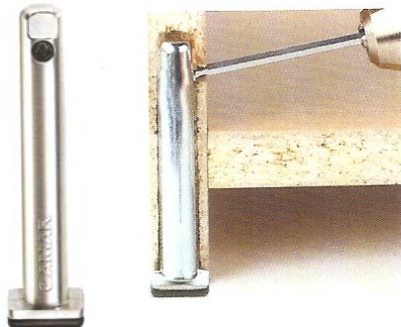

Art	Diametro	Altezza A mm	Regolazione
PI30632ZI	12	32	+ 18 mm
PI3067ZI	12	70	+ 25 mm

Tenuta 300 kg Carico massimo 150Kg. Carico sollevabile  
 Finale 15 mm X 20 mm

## ART.306 Diametro 14

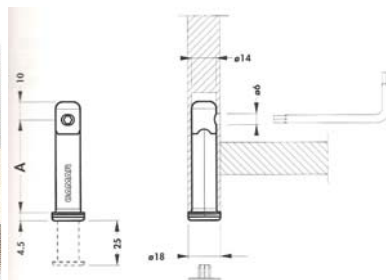
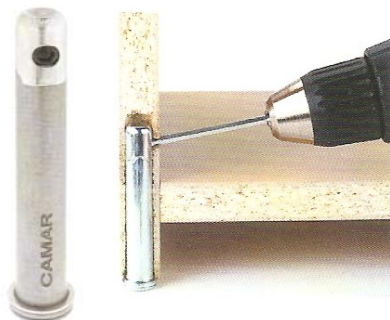

Art	Diametro	Altezza A mm	Regolazione
PI3065ZI	14	52	+ 25 mm

Tenuta 300 kg Carico massimo 150Kg. Carico sollevabile

# Piedini livellatori per mobili

## ART.717

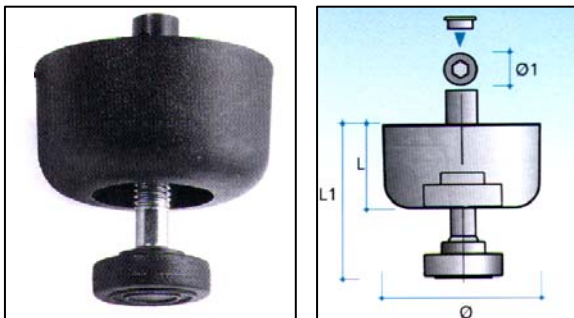

ART.	L mm	L1 mm	Ø mm	Ø1 mm	Finitura
PI71750NE	27	41	48	10	Nera
PIPI09NE	42	68	48	10	Nera

Materiale: Plastica  
 Registro: Chiave a brugola mm.4

## ART.13

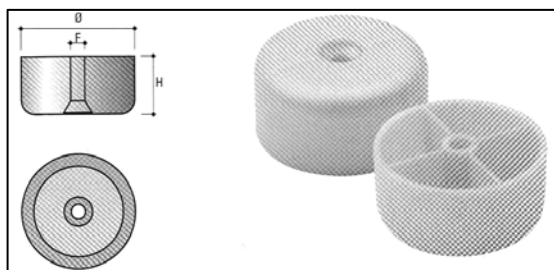

ART.	H mm	Ø mm	Ø foro mm	Materiale	Finitura
PIPI13NE	20	40	6	Plastica	Nera

## ART.900

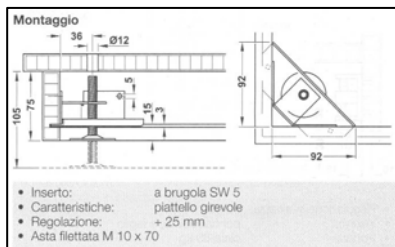
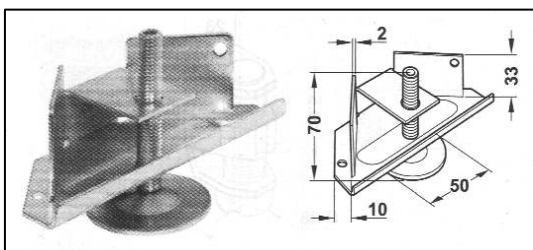

ART.	Finitura	M	Portata
PI900ZI	Zincato	10	150 kg

Regolazione+ 25mm  
 Piattello girevole  
 Insetto a brugola SW5